

- MATERIAL: 24 GAUGE GALVANNEALED STEEL
- UNIVERSAL END CAP: LOWER PORTION OF END CAP MAY BE FOLDED UP FOR CONTINUOUS APPLICATIONS WITHOUT DIFFUSER OR GRILLE DAMPER INTERFERENCE
- DESIGNED TO FIT HART & COOLEY LINEAR BAR GRILLES AND SLOT DIFFUSERS
- AVAILABLE IN LENGTHS FROM 12 TO 72 INCHES; WIDTHS 1-1/2 TO 16-1/2 INCHES
- INLET SIZES: 5 TO 12 INCH DIAMETERS
- OVALS ARE ALSO AVAILABLE
- INLET DAMPER AVAILABLE
- INTERNAL INSULATION AVAILABLE
- PLENUMS ARE ALSO AVAILABLE FOR SPECIAL APPLICATIONS. CONTACT FACTORY

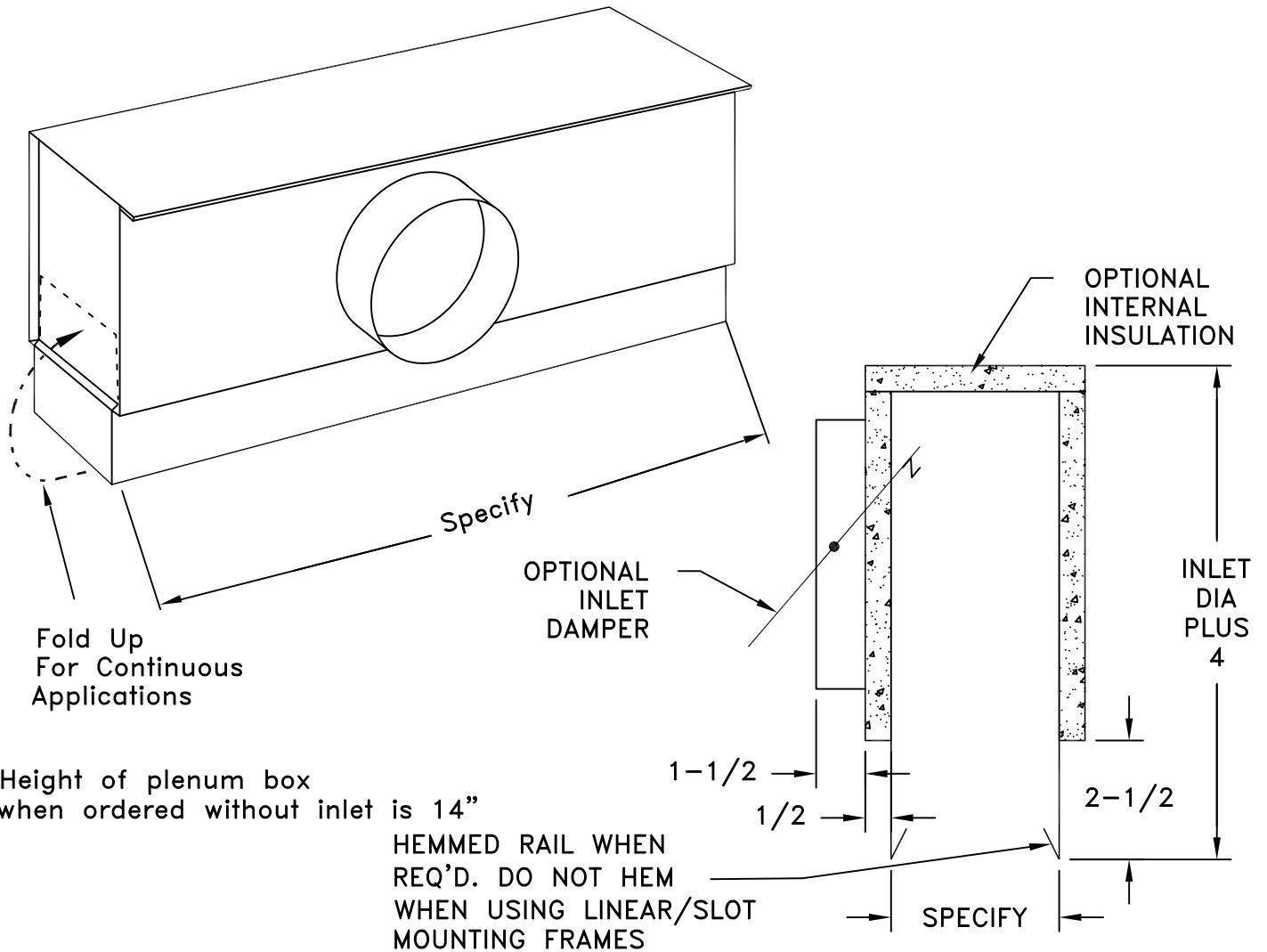

JOB NAME: _____	SUBMITTED BY: _____	DATE: 03/22/2017	AM-PSN/PSI
LOCATION: _____		DP SERIES Distribution Plenums	
ARCHITECT: _____			
ENGINEER: _____			
CONTRACTOR: _____			