

# AIRMATE

# SUBMITTAL DRAWING

- EXTRUDED ALUMINUM CONSTRUCTION WITH OPTIONAL OPPOSED BLADE DAMPER
- BARS ON 3/4 INCH CENTERS
- SCREW HOLE LOCATIONS STANDARD UNLESS OTHERWISE SPECIFIED
- MINIMUM SIZE: 6 X 4
- MAXIMUM SIZE: 48 X 48 ONE PIECE CONSTRUCTION
- AVAILABLE IN 1 INCH INCREMENTS
- FINISH: WHITE (W) ENAMEL OR SATIN ANODIZED (AL)

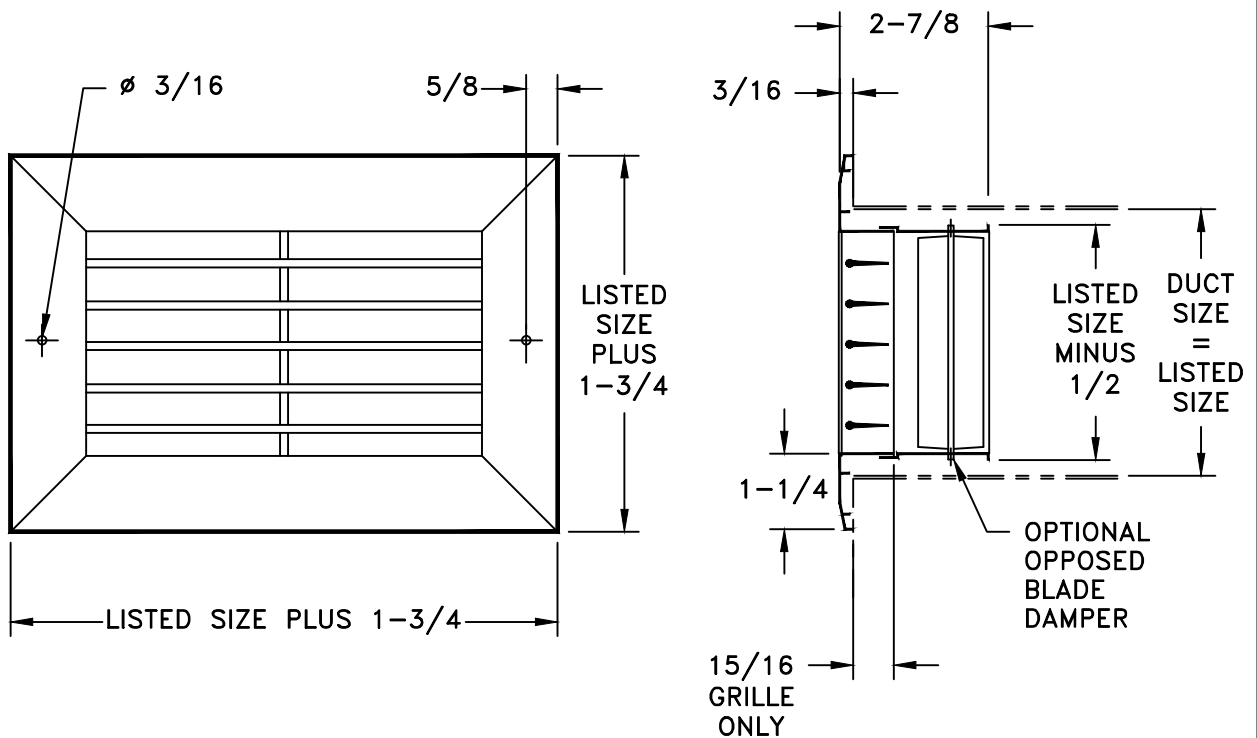

**E290- REGISTER ONLY**  
**E2900-REGISTER WITH OBD**

JOB NAME: \_\_\_\_\_  
 LOCATION: \_\_\_\_\_  
 ARCHITECT: \_\_\_\_\_  
 ENGINEER: \_\_\_\_\_  
 CONTRACTOR: \_\_\_\_\_

SUBMITTED BY: \_\_\_\_\_

DATE: 03/08/2021 | AM-E290,E290-O

**E290/E2900**  
 Fixed-Bar Return Air Grille  
 90-Degree