

- SINGLE (VERTICAL) AND DOUBLE (VERTICAL & HORIZONTAL) DEFLECTION
- ADJUSTABLE BLADES
- GASKETS ON MARGIN
- EACH SIZE COVERS A RANGE OF SPIRAL DUCT DIAMETERS (SEE CHART BELOW)
- OPTIONAL AIR SCOOP WITH FACE SCREW ADJUSTMENT
- MINIMUM SIZE 10 X 3, MAXIMUM SIZE 36 X 12 (SEE CHART BELOW)
- FINISH: WHITE (W) ENAMEL OR SATIN ANODIZED (SA)

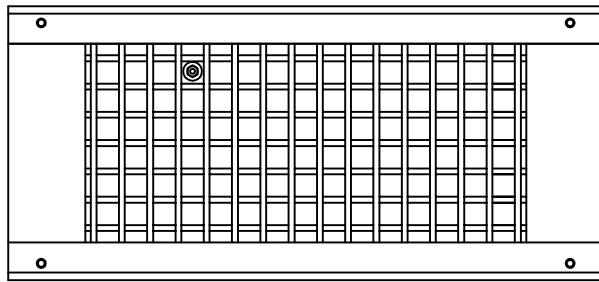

EUSD SHOWN

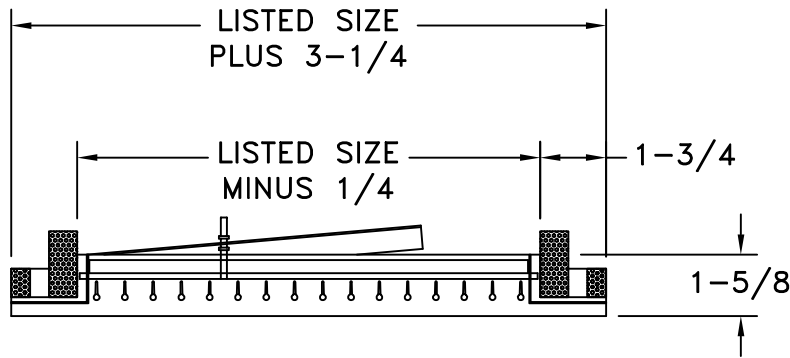
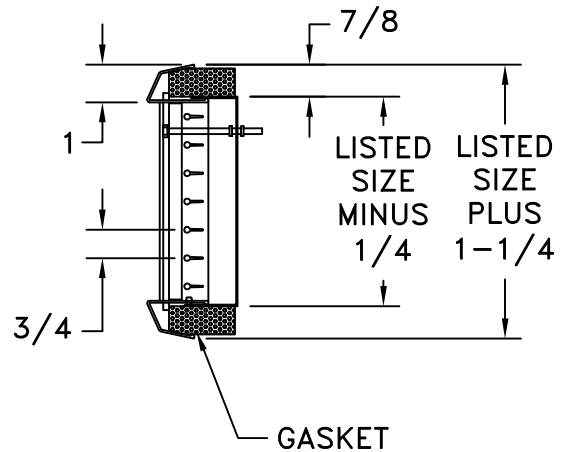

MINIMUM DUCT DIAMETER

HEIGHT	WIDTH								
	10	12	14	16	18	20	24	30	36
3	6	6	6	6	6	6	6	6	6
4	10	10	10	10	10	10	10	10	10
6	12	12	12	12	12	12	12	12	12
8	20	20	20	20	20	20	20	20	20
10	~	~	24	24	24	24	24	24	24
12	~	~	~	~	30	30	30	30	30

JOB NAME: _____
 LOCATION: _____
 ARCHITECT: _____
 ENGINEER: _____
 CONTRACTOR: _____

SUBMITTED BY: _____

DATE: 08/11/2014 AM-EUSD/EUSDD

EUSD/EUSDD
 Single And Double Deflection
 Aluminum
 Universal Spiral Duct Diffuser