

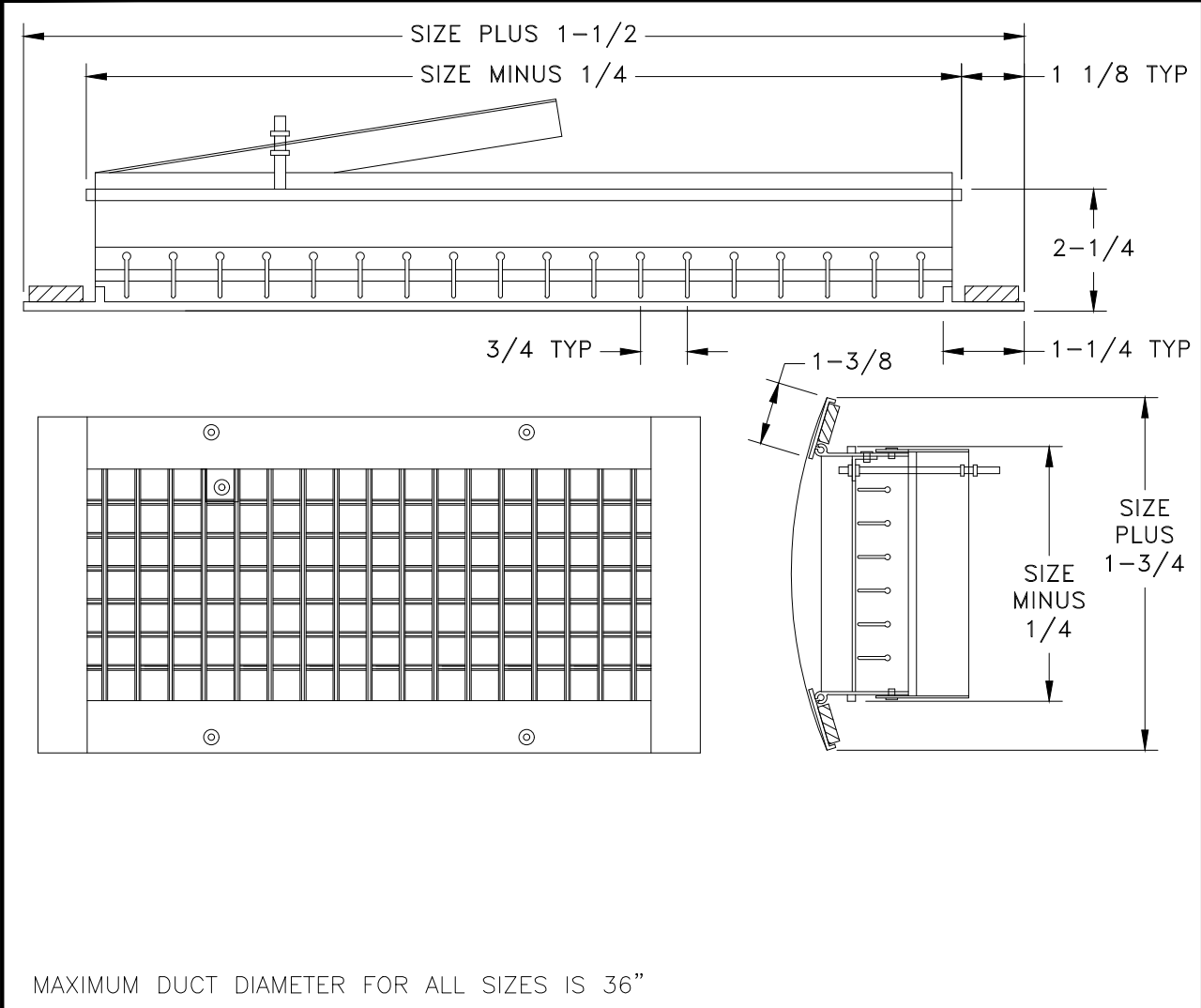

BY duravent™

SUBMITTAL DRAWING

- EXTRUDED ALUMINUM CONSTRUCTION
- SINGLE (VERTICAL) AND DOUBLE (VERTICAL & HORIZONTAL) DEFLECTION
- ADJUSTABLE BLADES
- GASKETS ON MARGIN
- OPTIONAL AIR SCOOP WITH FACE SCREW ADJUSTMENT
- MINIMUM SIZE 10 x 3 , MAXIMUM SIZE 36 x 12, SEE CHART BELOW
- FINISH: WHITE (W) ENAMEL OR SATIN ANODIZED (SA)



HEIGHT OF REGISTER	3"	4"	6"	8"	10"	12"
MIN: MAX DUCT DIAMETER, EVEN INCREMENTS ONLY	6" : 36"	8" : 36"	10" : 36"	12" : 36"	14" : 36"	16" : 36"

JOB NAME: _____
 LOCATION: _____
 ARCHITECT: _____
 ENGINEER: _____
 CONTRACTOR: _____

SUBMITTED BY: _____

DATE: 09/29/2022 | AM-ESD
ESD/ESDD
 Single And Double Deflection
 Aluminum
 Spiral Duct Diffuser